

DESCRIPTION AND MATERIAL	<ul style="list-style-type: none">• Body and engaging nut are 316 Stainless Steel, passivated per QQ-P-35 Type VI.• To 10,000 PSI in mated condition.• Bulkhead connector design open face pressure rated to 5000 PSI.• Contacts gold plated per MIL-G-45204.• Engaging nuts have Acme threads for rugged applications and for quick connection (shell size 15 has standard V thread).• Working voltage - 600 VDC (contact factory for high voltage applications).
CABLE	<ul style="list-style-type: none">• CCP, CCP-R/A and CCR are molded on standard 24" length of 16 AWG SO cable. IE55-1508 is molded on a standard 24" length of 18 AWG SO cable.• Other cable options available at customer's request.• BCR/FCR have 48" teflon leads, Type E per MIL 16878/4 16 AWG.• Un-Terminated versions of CCP available.
USES	<ul style="list-style-type: none">• Heavy Duty applications.• Hazardous environment.• Power Transmission.• Signal Telemetry.• ROV applications.
GUIDELINES	<ul style="list-style-type: none">• All mounting and sealing surfaces require a 32 finish.• Lubricate mating surfaces with 3M Silicone Lubricant or equivalent, DO NOT GREASE! Connectors must be lubricated on a regular basis.• Lubricate o-rings with Dow Corning #111 Valve Lubricant or equivalent.• Use Dust Caps and keep connectors clean to prevent damage in storage and service.• Keep o-ring grooves clean and avoid cuts, nicks and tears on rubber surfaces.• Elastomers can be seriously degraded if exposed to direct sunlight or high ozone levels for extended periods of time.• Clean plugs and receptacles with soap and fresh water. Rinse out with alcohol, allowing connector to air dry.• Replace o-rings when re-using connectors.
NOTE	<ul style="list-style-type: none">• Also available as inverted series, see following section.
Specifications for: SUBMINIATURE CONNECTOR (Bulletin 70 03/06)	<ul style="list-style-type: none">• Body and engaging nut are 6AL-4V Titanium. Engaging nut is Tiodized per AMS 2488 TYPE II.• Working voltage - 300 VDC.• IE55-1204/06-CCP, CCP-R/A and CCR are molded on standard 24" 22 AWG polyurethane jacketed cable. IE55W-1002/03-CCP, CCP-R/A and CCR are molded on standard 24" 20 AWG Belden cable.• IE55-1204/06-BCR/FCR are molded on standard 6" Teflon lead, Type E per MIL16878/4, 24 AWG. IE55W-1002/03-BCR/FCR are molded on standard 6" Teflon lead, Type E per MIL 16878/4, 22 AWG.• Mainly used on small sensor packages.• Light duty applications only.

IE55W-10

IE55(W) WET PLUGGABLE RUBBER MOLDED METAL SHELL SERIES

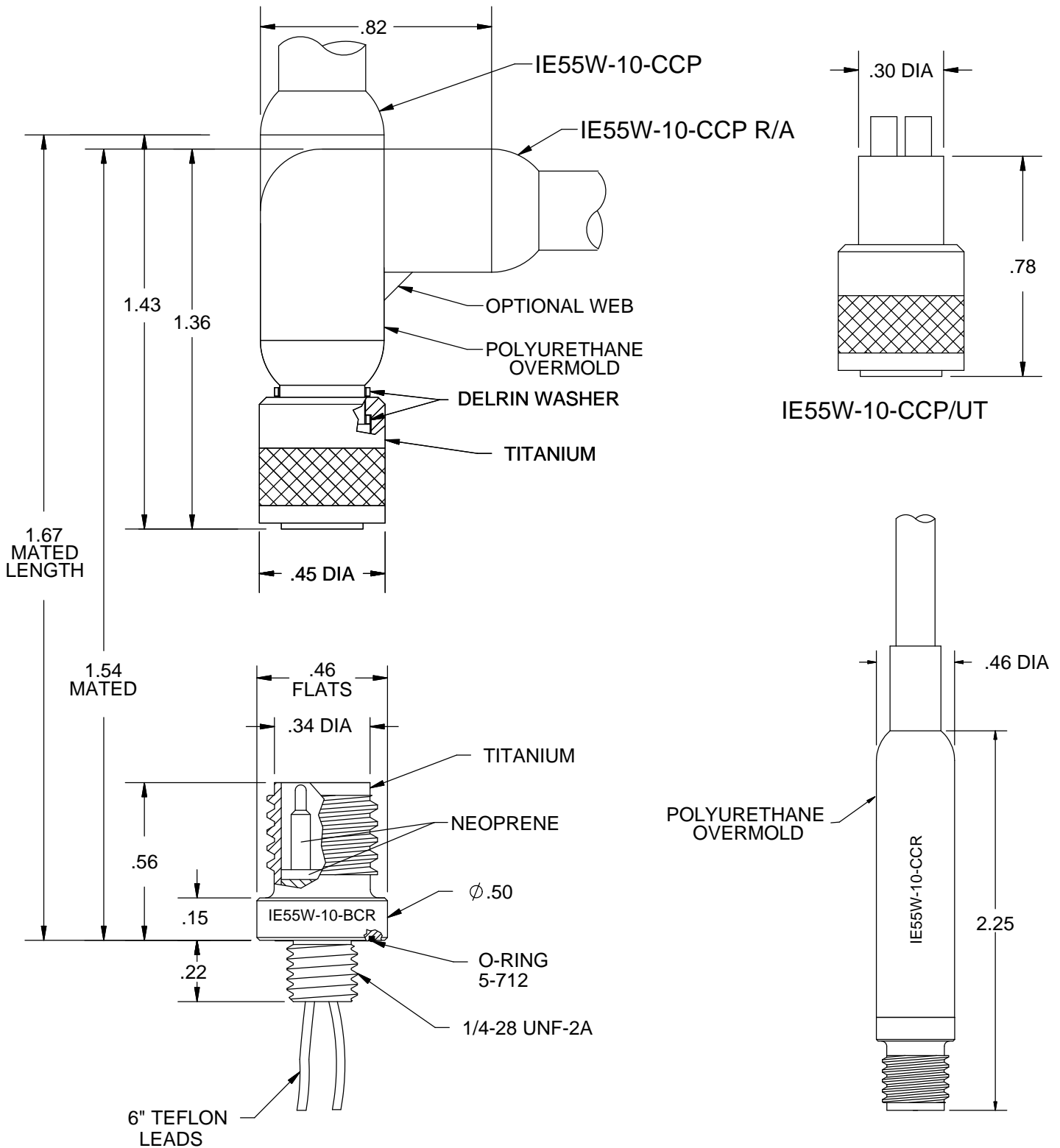

IE55W-10

IE55(W) WET PLUGGABLE RUBBER MOLDED METAL SHELL SERIES

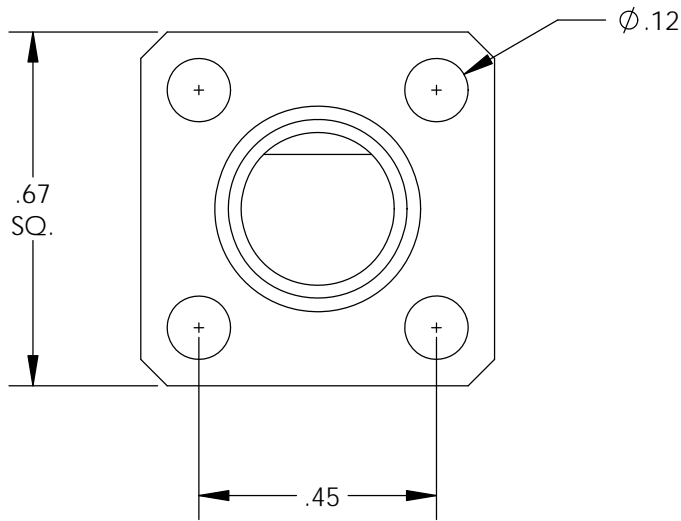

CONTACT CONFIGURATION (BCR FACE VIEW)

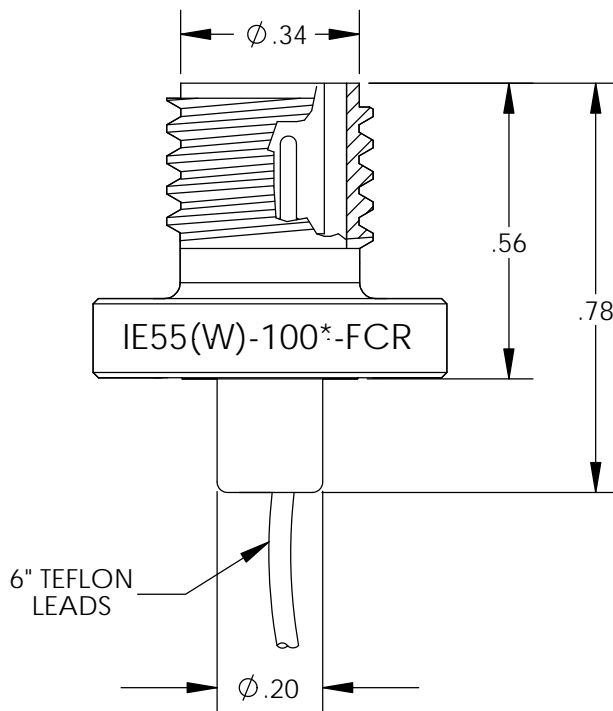
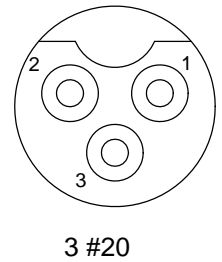
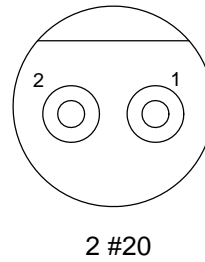

MATED PRESSURE RATING (psi)	10,000
MOUNTING TORQUE FOR BCR	not to exceed 15 in lbs
DUMMY PLUG FOR BCR	IE55W-10 *-SCP
DUMMY PLUG FOR CCP	IE55W-10* -SCR
* Specify number of contacts.	

IE55-12

IE55 RUBBER MOLDED
METAL SHELL SERIES

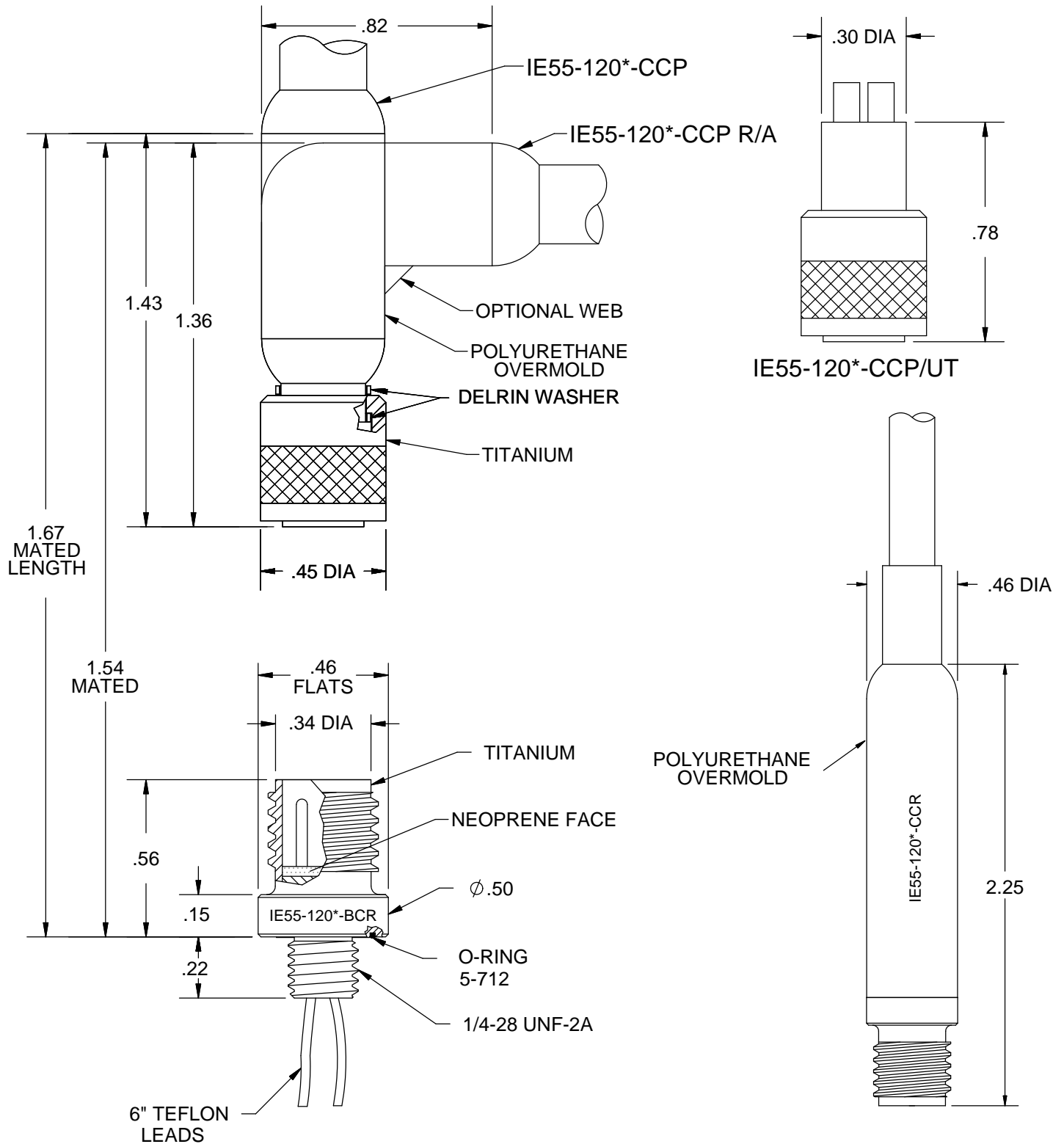

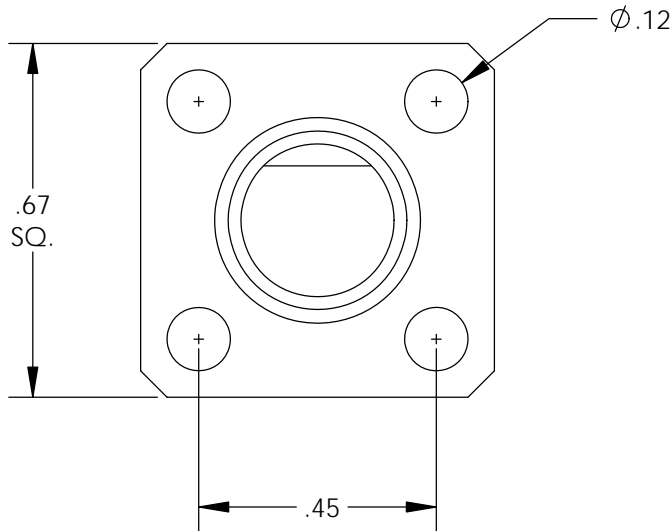

CONTACT CONFIGURATION
(BCR FACE VIEW)

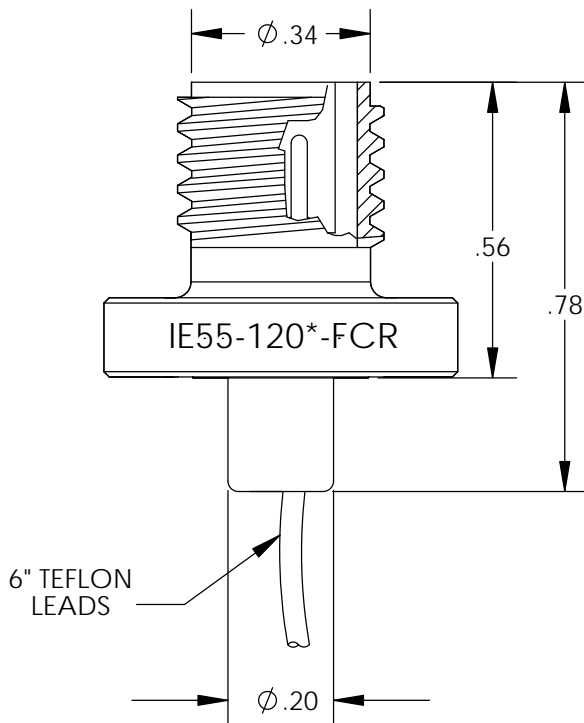
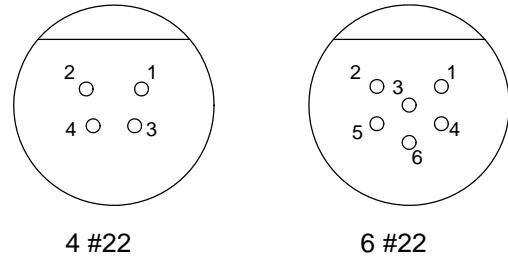

MATED PRESSURE RATING (psi)	10,000
MOUNTING TORQUE FOR BCR	not to exceed 15 in lbs
DUMMY PLUG FOR BCR	IE55-12*-SCP
DUMMY PLUG FOR CCP	IE55-12*-SCR
* Specify number of contacts	

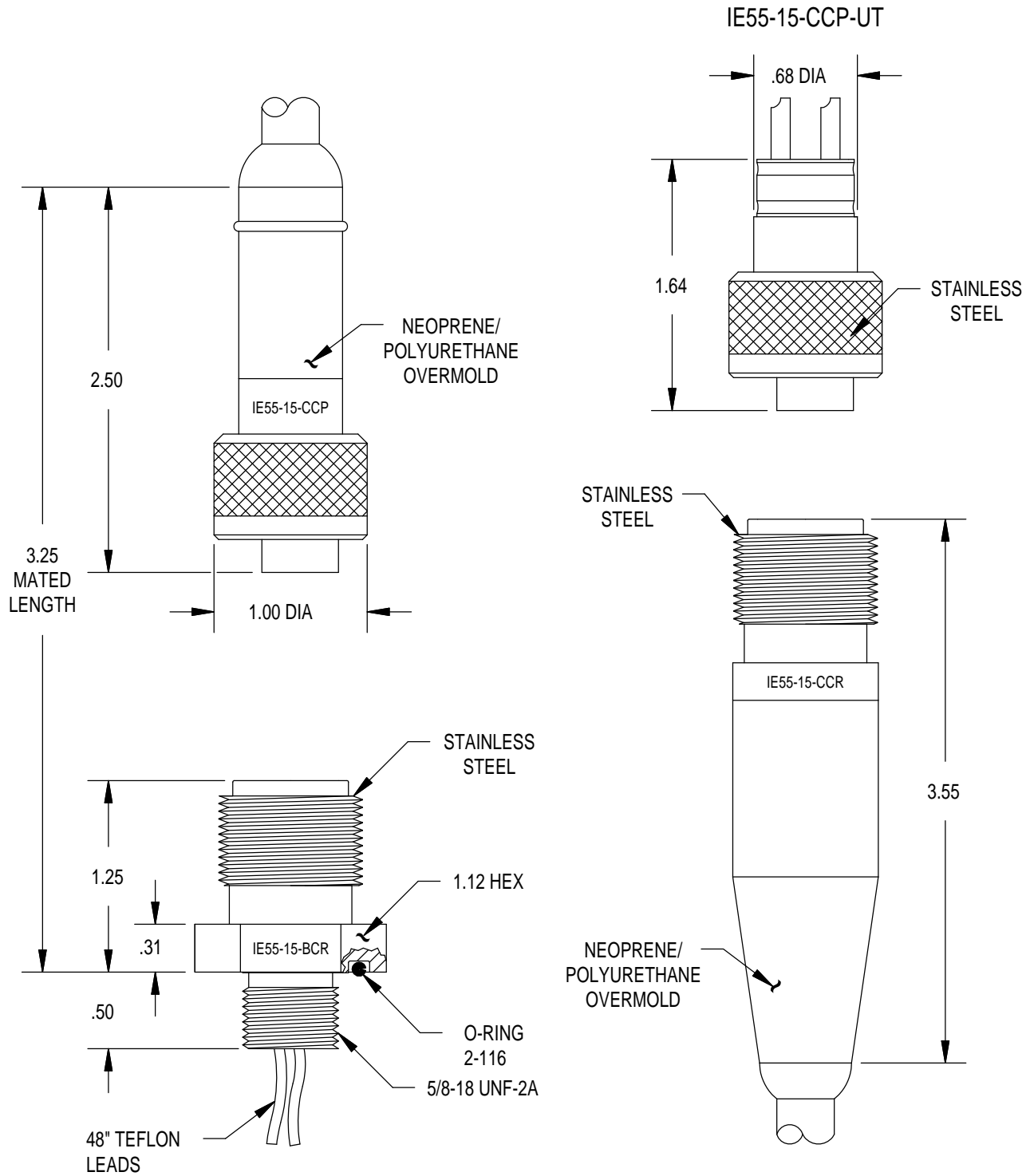

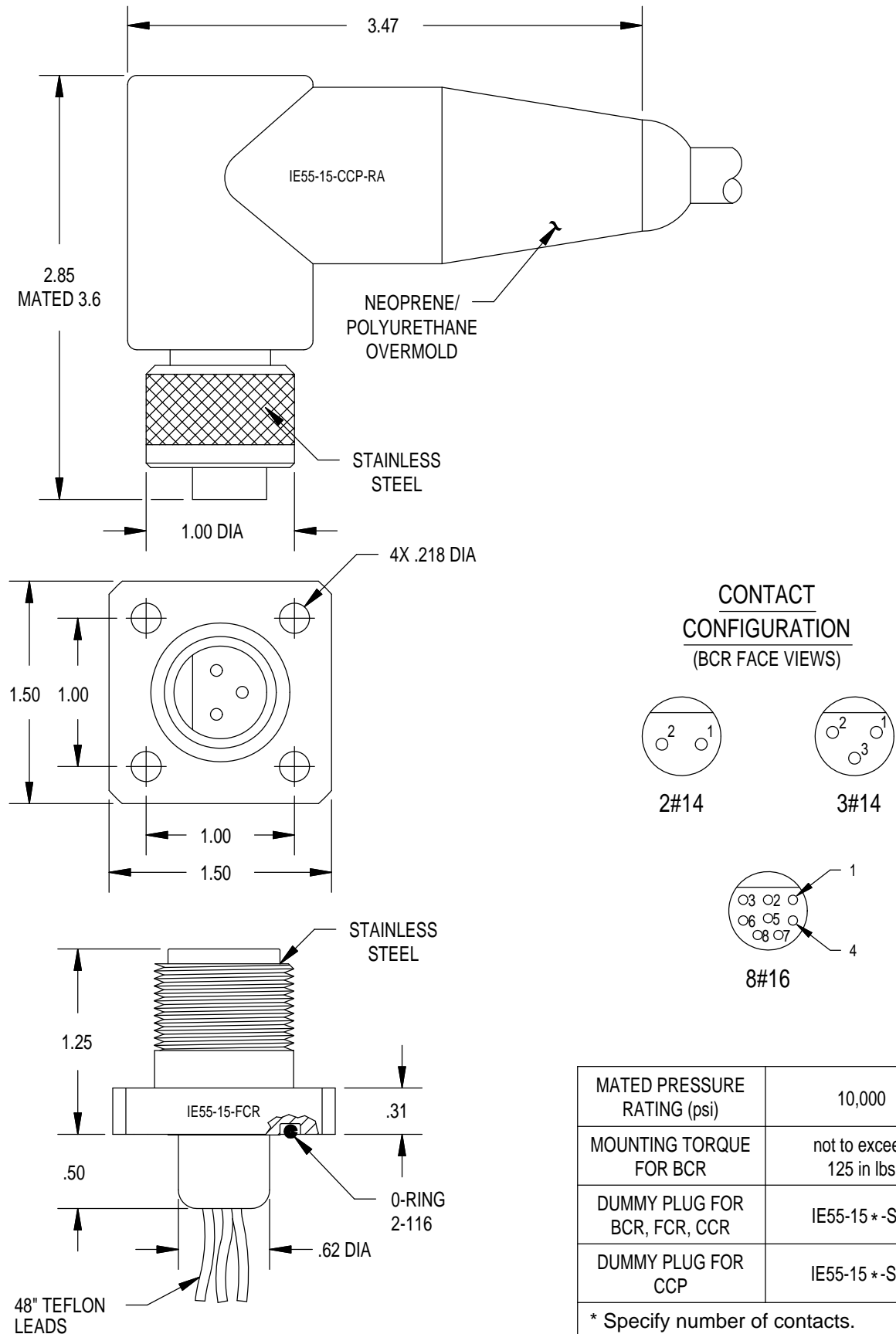

MATED PRESSURE RATING (psi)	10,000
MOUNTING TORQUE FOR BCR	not to exceed 125 in lbs
DUMMY PLUG FOR BCR, FCR, CCR	IE55-15 *-SCP
DUMMY PLUG FOR CCP	IE55-15 *-SCR
* Specify number of contacts.	

INVERTED AVAILABLE

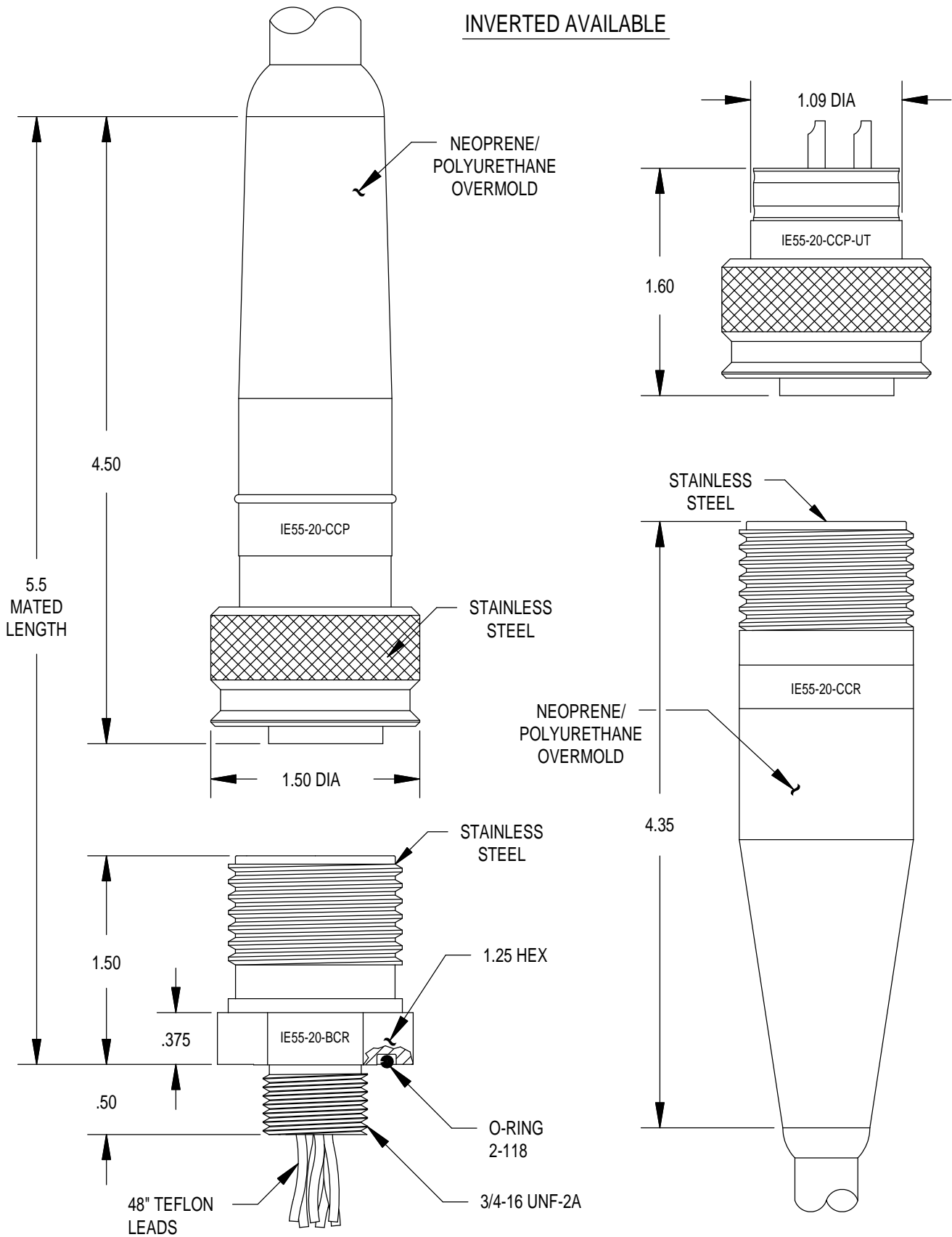

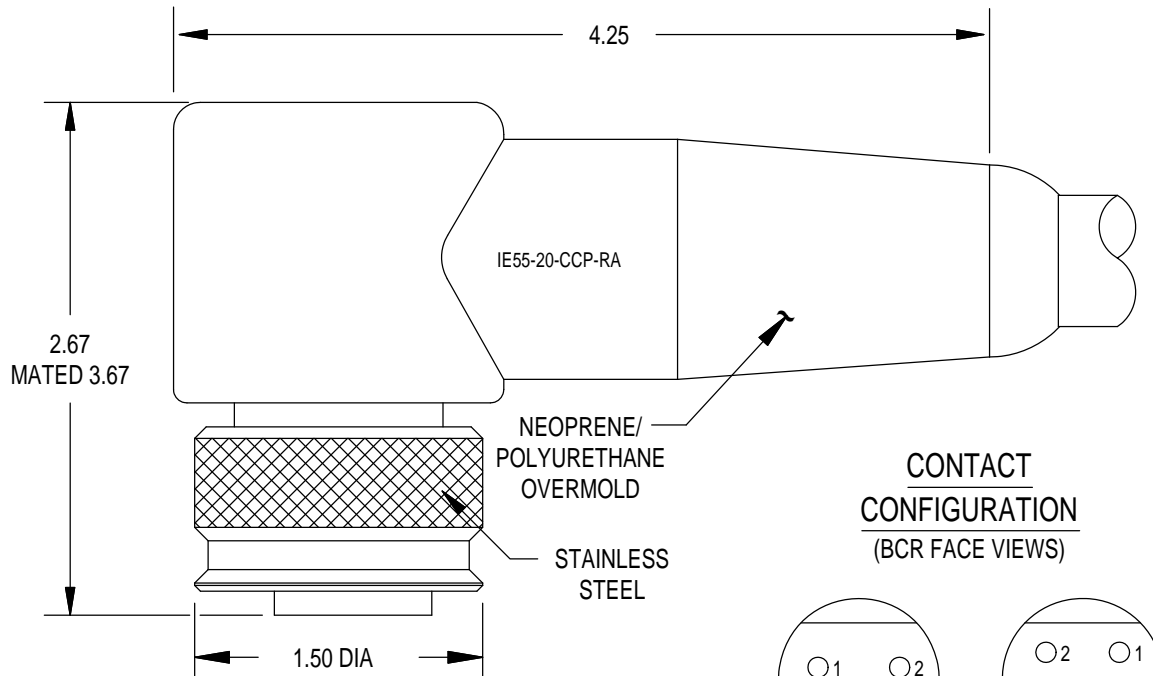

CONTACT CONFIGURATION
(BCR FACE VIEWS)

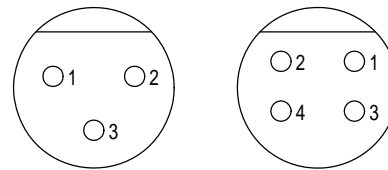

3#10

4#10

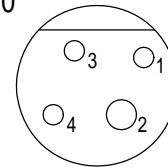

1#8 / 3#10
(High Voltage)

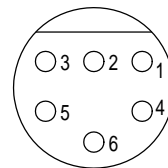

6#10

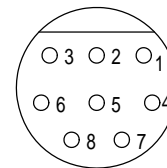

8#14

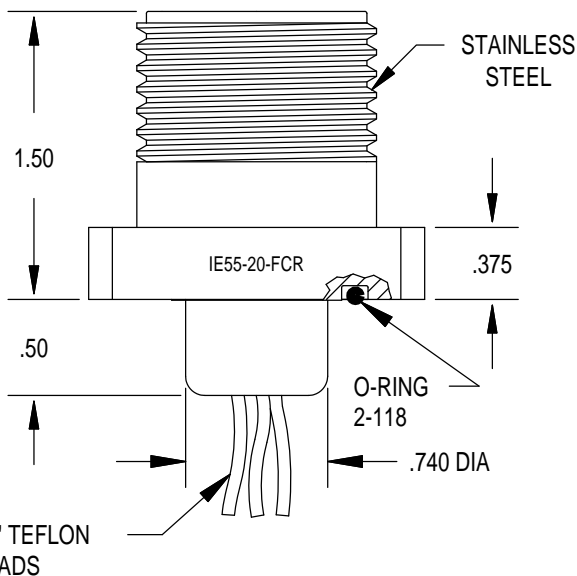
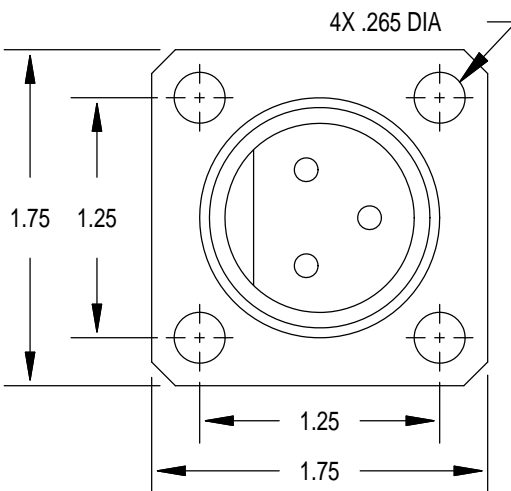

MATED PRESSURE RATING (psi)	10,000
MOUNTING TORQUE FOR BCR	not to exceed 165 in lbs
DUMMY PLUG FOR BCR, FCR, CCR	IE55-20 *-SCP
DUMMY PLUG FOR CCP	IE55-20 *-SCR
* Specify number of contacts. ** Available in high voltage	

IE55-24

IE55 RUBBER MOLDED
METAL SHELL SERIES

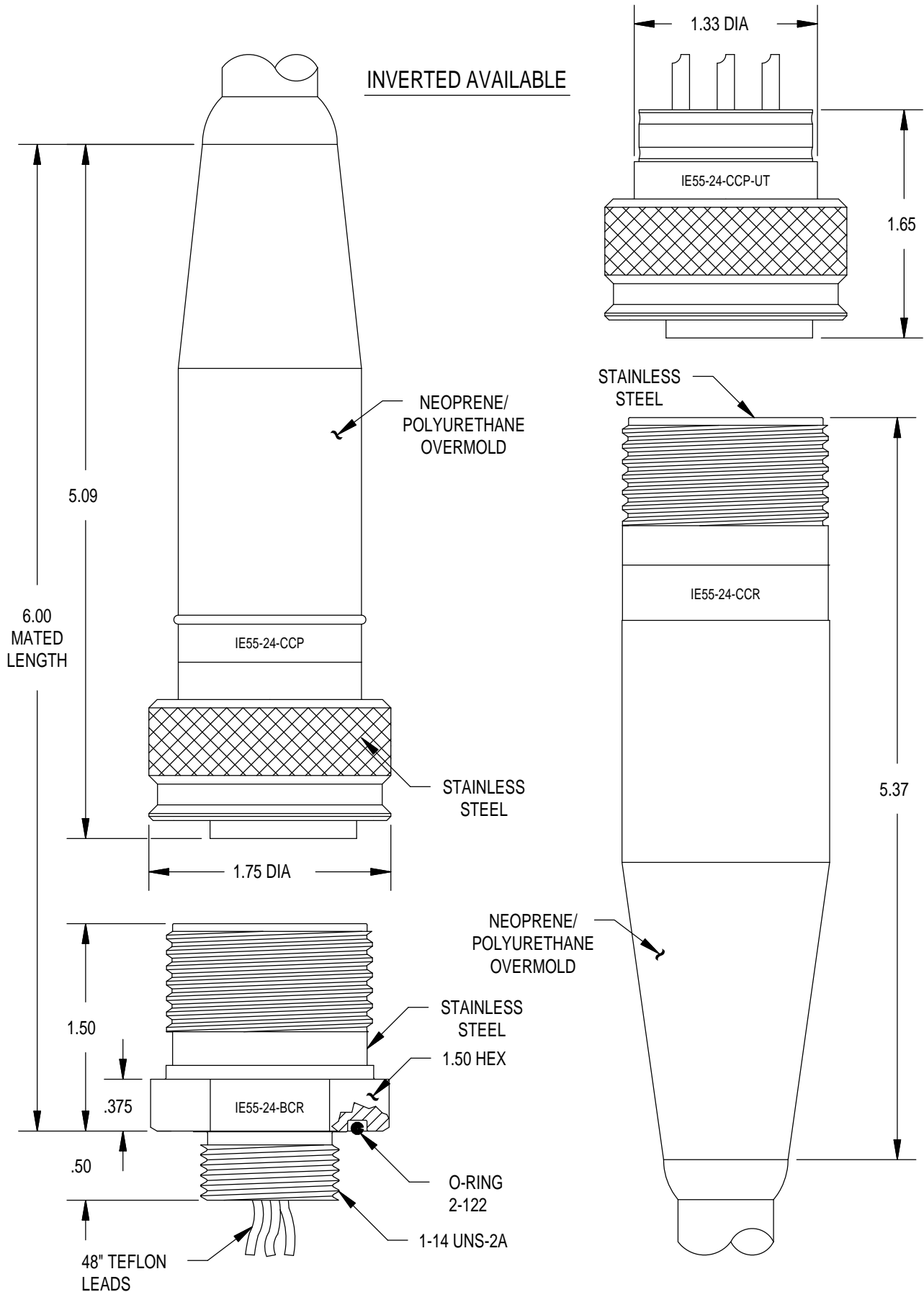

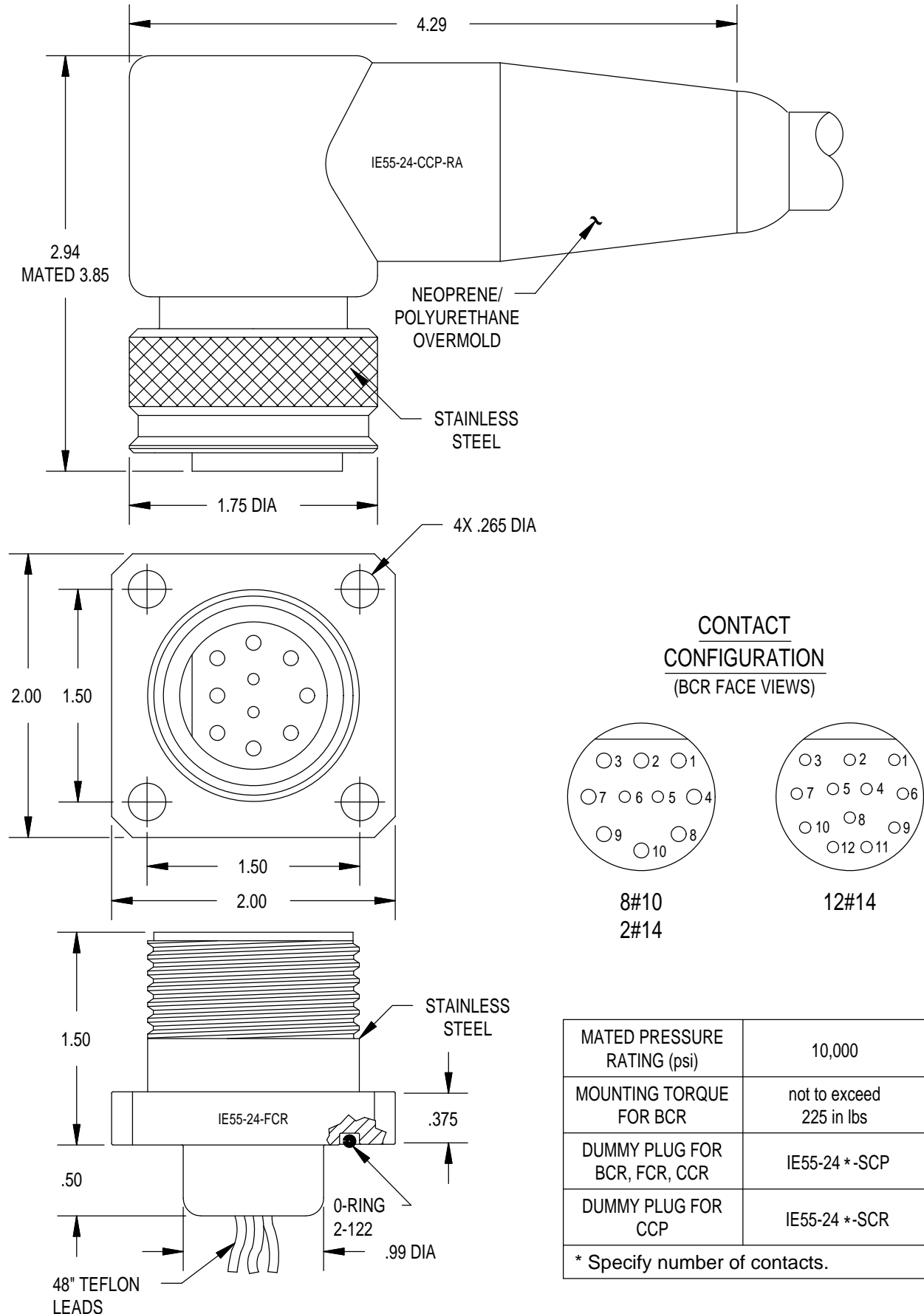

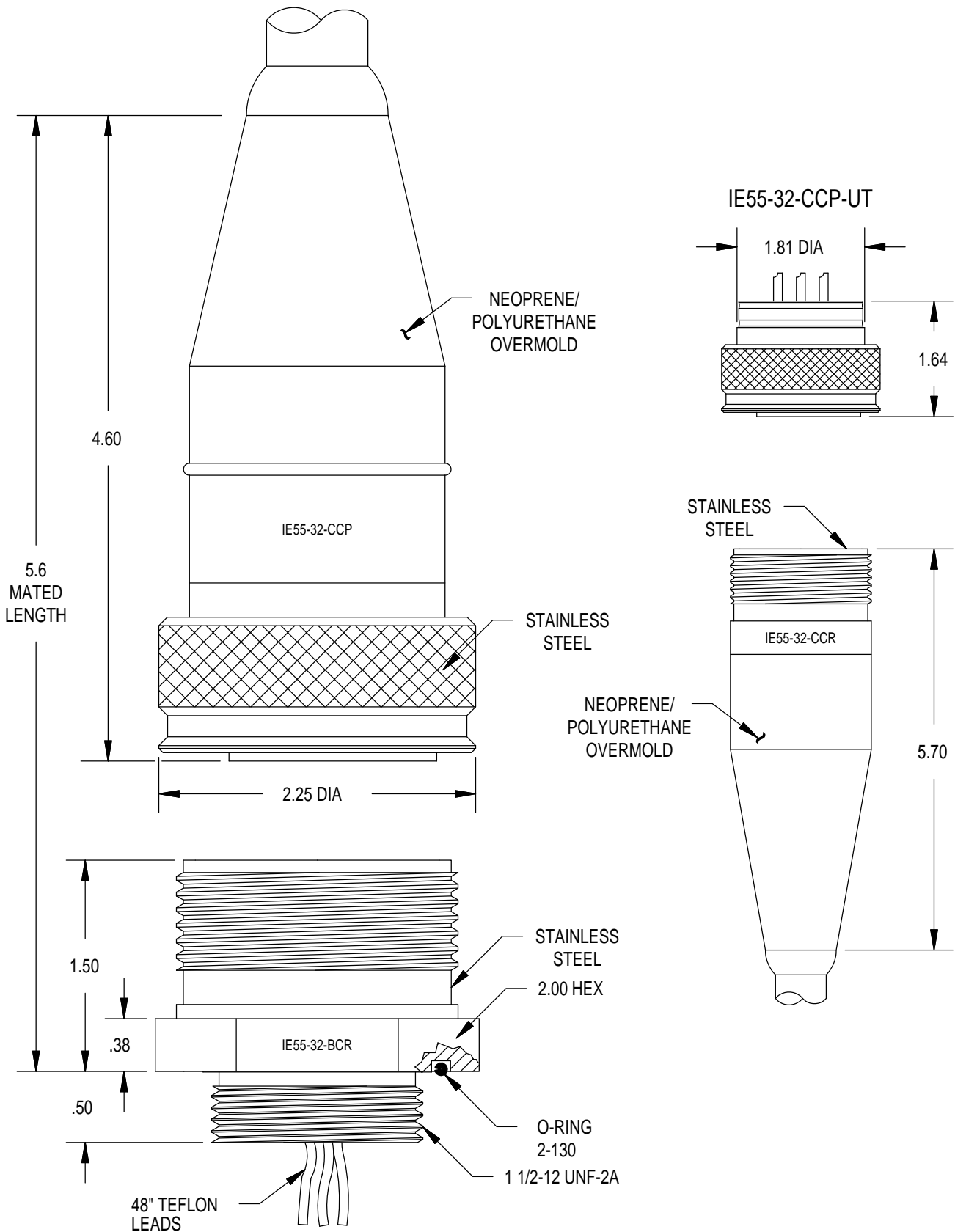

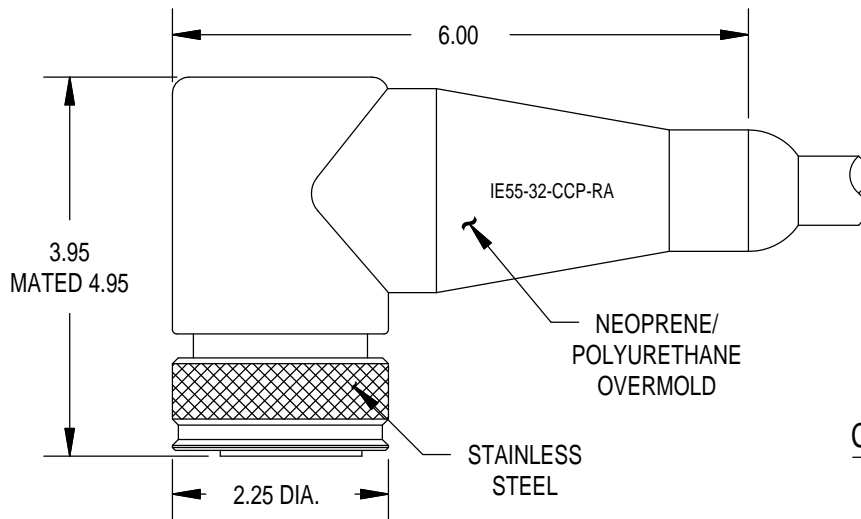

**CONTACT
CONFIGURATION**
(BCR FACE VIEWS)

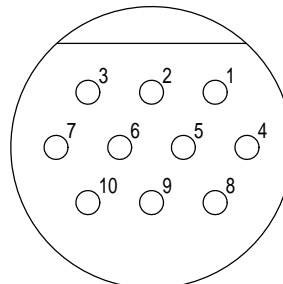
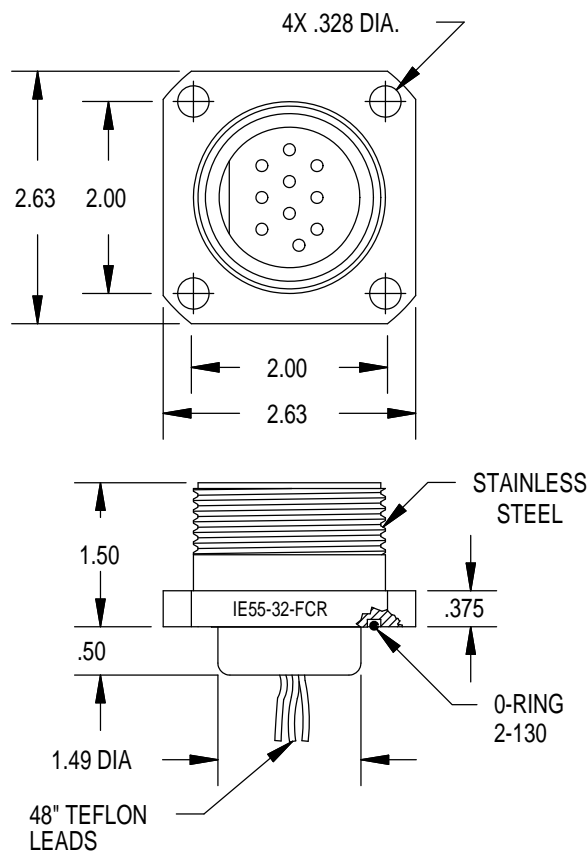

10#8

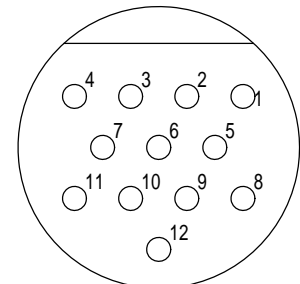

12#8

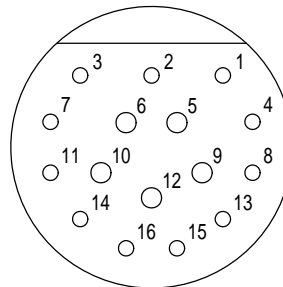

5#10
11#14

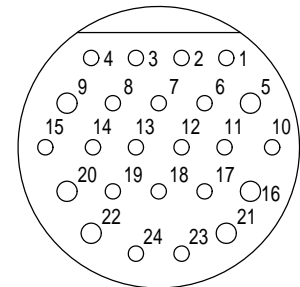

6#10
18#14

MATED PRESSURE RATING (psi)	10,000
MOUNTING TORQUE FOR BCR	not to exceed 335 in lbs
DUMMY PLUG FOR BCR, FCR, CCR	IE55-32 *-SCP
DUMMY PLUG FOR CCP	IE55-32 *-SCR
* Specify number of contacts.	

THIS PAGE INTENTIONALLY LEFT BLANK